

HARDWARE REFERENCE MANUAL

Quad Amp

4-Axis Digital Amplifier

3Ax-602646-xUxx

September 24, 2003



Copyright Information

© 2003 Delta Tau Data Systems, Inc. All rights reserved.

This document is furnished for the customers of Delta Tau Data Systems, Inc. Other uses are unauthorized without written permission of Delta Tau Data Systems, Inc. Information contained in this manual may be updated from time-to-time due to product improvements, etc., and may not conform in every respect to former issues.

To report errors or inconsistencies, call or email:

Delta Tau Data Systems, Inc. Technical Support

Phone: (818) 717-5656

Fax: (818) 998-7807

Email: support@deltatau.com

Website: <http://www.deltatau.com>

Operating Conditions

All Delta Tau Data Systems, Inc. motion controller products, accessories, and amplifiers contain static sensitive components that can be damaged by incorrect handling. When installing or handling Delta Tau Data Systems, Inc. products, avoid contact with highly insulated materials. Only qualified personnel should be allowed to handle this equipment.

In the case of industrial applications, we expect our products to be protected from hazardous or conductive materials and/or environments that could cause harm to the controller by damaging components or causing electrical shorts. When our products are used in an industrial environment, install them into an industrial electrical cabinet or industrial PC to protect them from excessive or corrosive moisture, abnormal ambient temperatures, and conductive materials. If Delta Tau Data Systems, Inc. products are directly exposed to hazardous or conductive materials and/or environments, we cannot guarantee their operation.

Table of Contents

| | |
|--|-----------|
| INTRODUCTION | 1 |
| Related Technical Documentation | 1 |
| Safety Summary | 1 |
| <i>Keep Away from Live Circuits</i> | 1 |
| <i>Live Circuit Contact Procedures</i> | 1 |
| Quad Amp Basic Specifications | 2 |
| <i>Physical Specifications</i> | 2 |
| <i>Electrical Specifications</i> | 2 |
| <i>Bus Supply, Control Supply and Shunt Specifications</i> | 2 |
| Protection | 6 |
| <i>Transient Voltage Filter</i> | 6 |
| <i>Transient Surge Suppressors</i> | 6 |
| <i>Fly-Back Diode</i> | 6 |
| <i>Fuses</i> | 6 |
| <i>Ground Fault (GF)</i> | 6 |
| Configurable Options | 7 |
| GETTING STARTED | 9 |
| Receiving and Handling | 9 |
| <i>Inspection upon Receipt</i> | 9 |
| <i>Storage Requirements</i> | 9 |
| <i>Prior to Installation</i> | 9 |
| Equipment Required | 9 |
| Installation Considerations and Options | 9 |
| <i>Option 3, 3A and 3B (External Mount)</i> | 9 |
| <i>Option 4 and 4A (Internal Mount)</i> | 9 |
| THEORY OF OPERATION | 11 |
| Operation | 11 |
| Configuration | 11 |
| <i>Logic Board</i> | 11 |
| <i>Current Sense Board</i> | 12 |
| <i>Firing Boards</i> | 12 |
| <i>Soft Start and Shunt Regulator</i> | 12 |
| <i>DC Bus Power Supply</i> | 12 |
| <i>Heat Dissipation</i> | 13 |
| <i>Shunt Considerations</i> | 13 |
| INSTALLATION | 15 |
| Wiring the Quad Amplifier System | 15 |
| <i>Quad Amplifier Channel Connections</i> | 15 |
| <i>Two Quad Amplifier Example</i> | 15 |
| <i>Typical Quad Amplifier Setup</i> | 15 |
| Non-Standard Quad Amplifier Setup | 16 |
| <i>Accessory Terminal Board (Acc-8F, Acc-24E2)</i> | 16 |
| <i>PWM Input Cables</i> | 16 |
| <i>Connectors</i> | 16 |
| Connecting Power Devices | 16 |
| <i>Main AC Input Power</i> | 19 |
| <i>Control AC Input Voltage</i> | 19 |
| <i>Bus Power Enable/Emergency Stop</i> | 21 |
| <i>Shunt and Bus</i> | 21 |
| <i>Bus</i> | 21 |
| <i>Bus Filter/Indicator</i> | 21 |
| <i>Motor Wiring</i> | 21 |
| <i>Motor Over-Temp Sensor</i> | 21 |

| | |
|---|-----------|
| <i>Jumpers, Potentiometers, Test Points, and LEDs</i> | 21 |
| Grounding | 25 |
| <i>General</i> | 25 |
| <i>Main Power Supply (DC Bus)</i> | 25 |
| <i>Motor</i> | 25 |
| PMAC2 I-Variables Setup..... | 25 |
| <i>Ix00</i> | 25 |
| <i>Ix01</i> | 25 |
| <i>Ix02</i> | 25 |
| <i>Ix25</i> | 25 |
| <i>Ix82</i> | 25 |
| <i>I900</i> | 25 |
| <i>I9n6</i> | 26 |
| Start-Up Procedures | 26 |
| <i>Power On Sequence</i> | 26 |
| <i>P2Setup</i> | 26 |
| TROUBLESHOOTING | 29 |
| Logic Fault Detection and Fault Codes | 29 |
| <i>Axis-Specific Faults</i> | 29 |
| <i>Global Faults</i> | 29 |
| Fault Reporting..... | 29 |
| <i>Serial Fault/Status Data</i> | 29 |
| <i>LED Fault Indicator</i> | 30 |
| <i>Global Fault Only</i> | 30 |
| <i>Global and Axis-Specific Faults</i> | 30 |
| <i>Axis-Specific Fault Only</i> | 30 |
| ILLUSTRATED REPAIR PARTS LIST | 33 |
| Purpose..... | 33 |
| Scope..... | 33 |
| How to Use the Repair Parts List | 33 |

INTRODUCTION

The Delta Tau Data Systems, Inc. 4-axis Digital Amplifier (Quad Amp) is a highly compact digital amplifier and power supply, packaged together to provide four axes of bi-directional (four quadrant) torque control for a variety of AC or DC brushless or AC induction motors. All control parameters including switching frequency and dead time are determined by software set-up of the controller, not in the amplifier.

The Quad Amp is designed to work in conjunction with the Delta Tau PMAC2 motion controller, which supports up to eight axes of motion control. The PMAC2 delivers Pulse Width Modulated (PWM) on/off signals to the Quad Amp power transistors. The Quad Amp simply isolates and level-shifts these signals, at the required frequency and magnitude, to obtain the desired torque, velocity, and position.

All feedback is processed by the PMAC2. The Quad Amp measures motor phase currents, digitizes them, and transmits them back to PMAC2 as a serial data stream. Position feedback data is sent directly back to the PMAC2 via the Acc-8F Digital Interface Board. The Quad Amp does not use or require any position data.

Related Technical Documentation

The following technical manuals are required to successfully install and operate the Delta Tau Quad Amp. These manuals should be included in the technical documentation package received with the Quad Amp. If any of these manuals are missing, contact Delta Tau before attempting installation.

| Manual Number | Manual Title |
|----------------|---|
| 3A0-602204-363 | PMAC User Manual and Software Reference with PMAC2 Addendum |
| 3A0-602775-363 | Acc-8F Digital Interface Board User Manual |
| 3A0-602598-363 | PMAC2 PC and PMAC2 Lite Hardware Reference Manual |
| 3A0-602413-363 | PMAC2 VME Hardware Reference Manual |
| 3A0-602643-363 | PMAC2 VME Ultralite Hardware Reference Manual |

Safety Summary

The following are general safety precautions not related to any specific procedures and therefore may not appear elsewhere in this publication. These are recommended precautions that personnel must understand, apply, and adhere to during the phases of installation, operation, and maintenance.

Keep Away from Live Circuits

Do not replace components or make adjustments inside equipment with power applied. Under certain conditions, dangerous potentials may exist when power has been turned off due to charges retained by capacitors. To avoid casualties, always remove power and allow 10 to 12 minutes for the bus capacitors to discharge before removing the cover.

Live Circuit Contact Procedures

Never attempt to remove a person from a live circuit with bare hands. To do so is to risk sure and sudden death. If a person is connected to a live circuit, the following steps should be taken:

- Call for help immediately
- De-energize the circuit, if possible.
- Use wooden or fiberglass hot stick to pull the person free of the circuit.
- Apply cardiopulmonary resuscitation (CPR) if the person has stopped breathing or is in cardiac arrest.
- Obtain immediate medical assistance.

Quad Amp Basic Specifications

Physical Specifications

Size (See Figure 1)

- Height: 22.0 Inches
- Width: 10.5 Inches
- Length:
 - 5.125 Inches (without mounting option)
 - 9.031 Inches (with mounting option)

Weight

- 60 lb. (27.3 kg)

Temperature

Storage: -20 degrees C to +85 degrees C

Operating: 0 degrees C to +60 degrees C (Unit is disabled if heat sink temperature exceeds 80 degrees C)

Relative Humidity

10% to 95%, non-condensing

Electrical Specifications

Switching Frequency

7.5 kHz (Nominal)

15 kHz (Maximum)

Cooling

Options 3B, 4, and 4A: Forced Air (Internal)

Options 3 and 3A: Customer supplied (external)

Protection

Fuses:

F201 - Shunt Regulator IGBT and Shunt Resistors

F202 - Logic Power Supply

3-Phase In-Line Circuit Breaker (Optional)

Bus Supply, Control Supply and Shunt Specifications

120V/208V/230V Quad Amplifier Specifications

| | | |
|--|----------------------------------|---------------|
| Main AC Input Voltage/Current (L1, L2, L3) | 120 VAC, single phase | For demo only |
| Input voltage | 208 VAC, three phase | |
| | 230 VAC, three phase | |
| Input current/phase, continuous. | 25 A @ 12.5 HP continuous output | |
| | 60 A @ 25 HP continuous output | |
| | 72 A @ 33 HP continuous output | |
| Frequency | 50/60 Hz ±2 | |
| Control AC Input Voltage/Current (Connector C3) | | |
| (Dependent on Option Ordered) | | |
| Input voltage (Selectable) | 120 VAC (+/- 10 %), single phase | |
| | 208 VAC (+/- 10 %), single phase | |
| | 230 VAC (+/- 10 %), single phase | |
| Min. required input current (RMS) | 3 A @ 120VAC | |
| | 1.5 A @ 230 VAC | |
| Frequency | 50/60 Hz ±2 | |

| | | |
|---|--|---------------|
| Main DC bus Voltage | 170 VDC (120 VAC line input) (L1, L2) 300 VDC (208 VAC line input) (L1, L2, L3) 325 VDC (230 VAC line input) (L1, L2, L3) | For demo only |
| Internal Shunt Resistor | | |
| Resistance | 15 Ohm | |
| Resistor power | 1.8 kW | |
| External Shunt Resistor (Optional) | | |
| Resistance | 8.5 Ohm | |
| Resistor power | 2.8 kW | |
| Soft Start charge time | 1 Sec | |
| Minimum output inductance | 3 mH | |

380/460/480V Quad Amplifier Specifications

Main AC Input Voltage/Current (L1, L2, L3)

| | |
|---|--|
| Input voltage | 380 VAC, three phase 460 VAC, three phase 480 VAC, three phase |
| Input current/phase, continuous. | 10 A @ 12.5 HP continuous output 25 A @ 25 HP continuous output 36 A @ 33 HP continuous output |
| Frequency | 50/60 Hz ±2 |

Control AC Input Voltage/Current (Connector C3)

(Dependent on Option Ordered)

| | |
|--|--|
| Input voltage (Selectable) | 120 VAC (+/- 10 %), single phase 208 VAC (+/- 10 %), single phase 230 VAC (+/- 10 %), single phase 380 VAC (+/- 10 %), single phase 460 VAC (+/- 10 %), single phase 480 VAC (+/- 10 %), single phase |
| Min. required input current (RMS) | 3 A @ 120VAC 1.5 A @ 230 VAC 1A @ 380VAC 0.75 A @ 460 VAC |
| Frequency | 50/60 Hz ±2 |

Main DC bus Voltage

| |
|---|
| 537 VDC (380 VAC line input) (L1, L2, L3) |
| 650 VDC (460 VAC line input) (L1, L2, L3) |
| 680 VDC (480 VAC line input) (L1, L2, L3) |

Internal Shunt Resistor

| | |
|----------------|--------|
| Resistance | 30 Ohm |
| Resistor power | 0.6 kW |

External Shunt Resistor

| | |
|----------------|-----------|
| Resistance | 12.75 Ohm |
| Resistor power | 4.2 kW |

Soft Start charge time

1 Sec

Minimum output inductance

3 mH

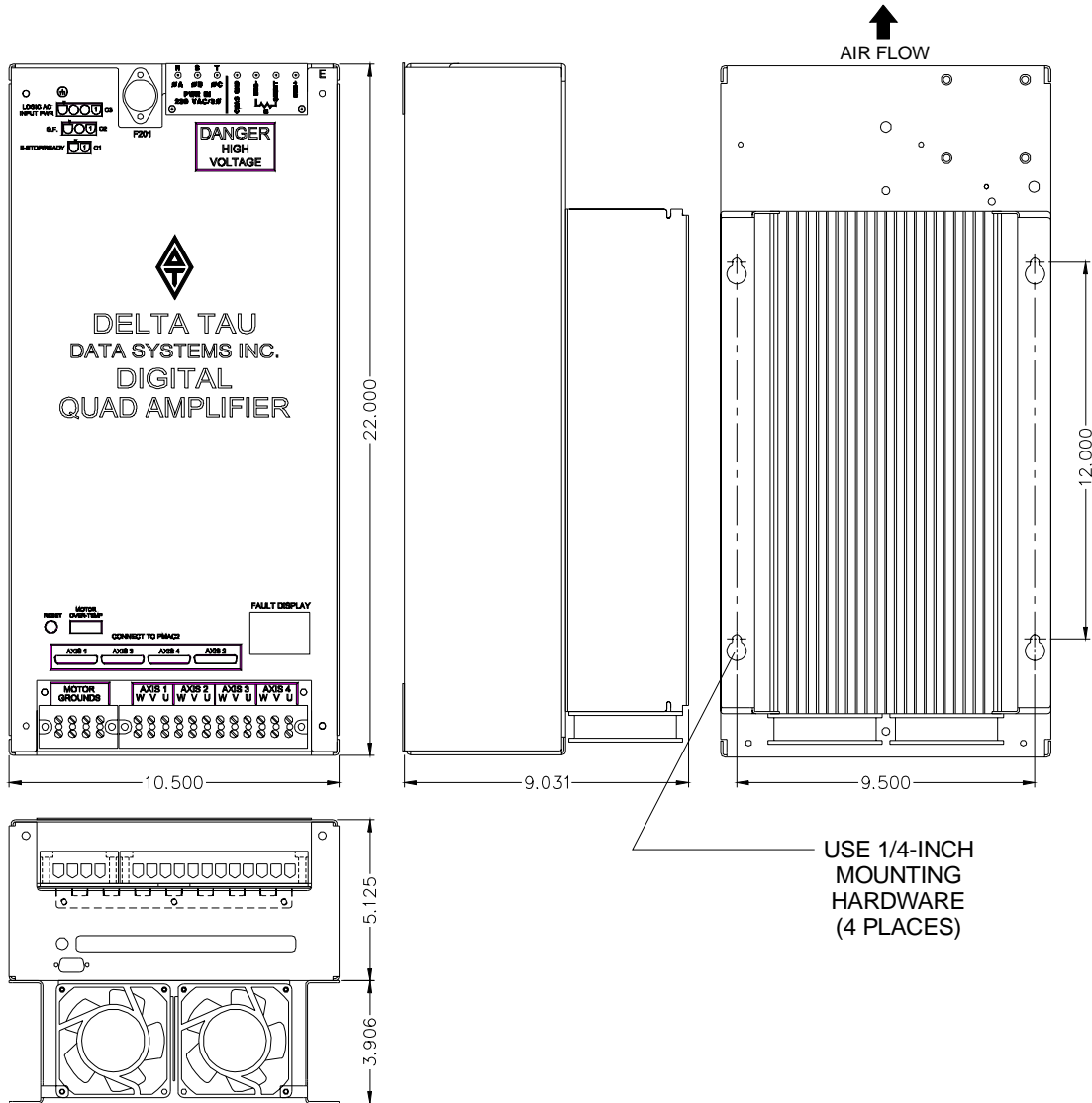

Figure 1 Quad Amp Specifications

Output Specifications for 120/208/230 VAC Amplifier

Up to four blocks (options) can be selected in any power combination. The total power cannot exceed 33 HP.

Note:

When 30HP is selected only two additional axes may be used (three total instead of four).

| | Opt 5 | Opt 6 | Opt 7 | Opt 8 | Opt 9 | Opt 10 | Opt 11 | Opt 12 | Opt 13 | Opt 14 |
|----------------------------------|---------------------------|------------------|----------------|----------------|--------------------|------------------|-----------------|----------------|----------------|------------------|
| Continuous HP(100%) | 0.75 HP 0.56 kW | 1.5 HP 1.1 kW | 2 HP 1.5 kW | 3 HP 2.2 kW | 5 HP 3.7 kW | 7.5 HP 5.6 kW | 10 HP 7.5 kW | 15 HP 11 kW | 20 HP 15 kW | 30 HP 22.5 kW |
| Continuous current (RMS) | 2 A | 4 A | 5 A | 7 A | 15 A | 20 A | 25 A | 35 A | 50 A | 75 A |
| Continuous 2 min HP(200%) | 1.5 HP 1.1 kW | 3 HP 2.2 kW | 4 HP 3 kW | 6 HP 4.5 kW | 10 HP 7.5 kW | 15 HP 11 kW | 20 HP 15 kW | 30 HP 22 kW | 40 HP 30 kW | 60 HP 45 kW |
| Peak 2 sec HP(300%) | 2.25 HP 1.7 kW | 4.5 HP 3.4 kW | 6 HP 4.5 kW | 9 HP 6.7 kW | 15 HP 11 kW | 22.5 HP 17 kW | 30 HP 22 kW | 45 HP 34 kW | 60 HP 45 kW | 90 HP 67 kW |
| Peak 2 sec current | 5 A | 12 A | 15 A | 21 A | 36 A | 54 A | 75 A | 100 A | 150 A | 200 A |
| PWM dead time | 2.3 μ s(PMAC2default) | | | | PMAC2 programmable | | | | | |

Output Specifications for 380/460 VAC Amplifier

Up to four blocks (options) can be selected in any power combination.

The total power cannot exceed 35 Hp.

Note:

When 30HP is selected, only two additional axes may be used (three total instead of four).

| | Opt 15 | Opt 16 | Opt 17 | Opt 18 | Opt 19 | Opt 20 |
|-----------------------------------|-----------------------------|----------------|--------------------|----------------|----------------|----------------|
| Continuous HP (100 %) | 2 HP | 3 HP | 5 HP | 10 HP | 20 HP | 30 HP |
| Continuous current (RMS) | 2.5 A | 3.5 A | 6 A | 12.5 A | 25 A | 35 A |
| Continuous 2 min HP (200%) | 4 HP 3 kW | 6 HP 4.5 kW | 10 HP 7.5 kW | 20 HP 15 kW | 40 HP 30 kW | 60 HP 45 kW |
| Peak 2 sec HP (300%) | 6 HP 4.5 kW | 9 HP 6.7 kW | 15 HP 11 kW | 30 HP 22 kW | 60 HP 45 kW | 90 HP 67 kW |
| Peak 2 sec current | 7.5 A | 10.5 A | 18 A | 40 A | 75 A | 100 A |
| PWM dead-time | 2.3 μ s (PMAC2 default) | | PMAC2 programmable | | | |

Protection

There are several layers of protection built into the amplifier, including transient voltage filters, transient surge suppressors, fuses, a flyback diode, and a variety of fault detection circuits. These are discussed in the following paragraphs and in the Troubleshooting Chapter.

Transient Voltage Filter

The transient voltage RC filter is used as a means of suppressing inductive transients and is located across the single phase Control AC input voltage connector C3.

Transient Surge Suppressors

Transient surge suppressors (also referred to as metal oxide varistors or MOVs) are connected across all three input phases (L1, L2, L3) of the Main AC input power. They are located on a circuit board attached to the top of the bridge power rectifier. The primary function of these devices is to absorb high-level energy pulses (spikes).

Fly-Back Diode

The fly-back diode clamps inductive spikes that may be generated across the external shunt resistors when the shunt IGBT is turned off. The diode is connected across the external shunt resistor terminals.

Fuses

The primary hardware protection is fuses, which are mounted within the Quad Amplifier chassis.

Fuse F201

F201 is a 30 Amp long delay fuse, located externally on the top cover of the Quad Amplifier. Fuse F201 is connected to the output of the shunt regulator IGBT and to the internal shunt regulator resistors. Fuse F201 protects the shunt regulator IGBT and the internal shunt resistors from over current damage.

Fuse F202

F202 is a 4-Amp Slo-Blo fuse located under the Quad Amplifier cover, next to the control AC input power supply transformer. This fuse is connected between incoming AC control input power connector C3 and control input AC power transformer T201. Fuse F202 protects the primary input windings of the control power supply transformer against overloads.

Ground Fault (GF)

The Ground Fault Detector is a self-powered circuit that continuously samples the AC line currents via a toroid around the incoming three phase lines. If there is more current flowing into the amplifier than out, the ground fault circuit will activate and shut down the Quad Amplifier with a soft start fault.

Configurable Options

Each Quad Amplifier is shipped with an Identification Tag (see Figure 1). The identification tag is attached to the top panel of the Quad Amplifier. It indicates the rating of each axis, the AC operating voltage, and the control input voltage. Since every Quad Amplifier is a custom unit, Delta Tau would like to emphasize that each user should inspect the equipment and see that the correct unit has been supplied. Contact Delta Tau immediately if there are questions regarding the shipment. The following tables define the Delta Tau part numbers, for the Delta Tau Digital Quad Amplifier and its configurable options.

| Part No. | Item | Description | Note |
|----------------|---|--|---|
| 500-602645-102 | Basic Quad Amplifier. | Basic Quad Amplifier includes: Fans, built-in shunt and soft start circuits. | Must choose either option 1, 2 or 2A with basic quad P/N. |
| 301-QADAMP-OPT | Quad Amplifier Basic P.S. Option 1 | For 10 HP or less Power supply 50 amp and small HS | Control Voltage is Selectable: 120 VAC |
| 302-QADAMP-OPT | Quad Amplifier upgrade Option 2 | Over 10 HP up to 33 HP Power supply 100 amp and large HS | 208 VAC 230 VAC |
| 3A2-QADAMP-OPT | Quad Amplifier High voltage upgrade Option 2A | 380/460 VAC version Power supply 75 amp and large HS | 380 VAC 460 VAC 480 VAC |

| Power Blocks | Item | Description | Note |
|----------------|--------------------------|---|------|
| 305-QADAMP-OPT | Power Block Option 5 | 10 Amp, 600V *** Block, 0.75 HP Cont. | |
| 306-QADAMP-OPT | Power Block Option 6 | 15 Amp, 600V*** Block, 1.5 HP Cont. | |
| 307-QADAMP-OPT | Power Block Option 7 | 20 Amp, 600V*** Block, 2 HP Cont. | |
| 308-QADAMP-OPT | Power Block Option 8 | 30 Amp, 600V*** Block, 3 HP Cont. | |
| 309-QADAMP-OPT | Power Block Option 9 | 50 Amp, 600V*** Block, 5 HP Cont. | |
| 310-QADAMP-OPT | Power Block Option10 ** | 50 AMP, 600V*** Block, 7.5 HP Cont. | |
| 311-QADAMP-OPT | Power Block Option11 ** | 75 Amp, 600V*** Block, 10 HP Cont. | |
| 312-QADAMP-OPT | Power Block Option12 ** | 100 Amp, 600V*** Block, 15 HP Cont. | |
| 313-QADAMP-OPT | Power Block Option13 ** | 150 Amp, 600V*** Block, 20 HP Cont. | |
| 314-QADAMP-OPT | Power Block Option14 ** | 200 Amp, 600V*** Block, 30 HP Cont. * | |
| 315-QADAMP-OPT | Power Block Option15 | 10 Amp, 1200V*** Block, 2 HP Cont.* | |
| 316-QADAMP-OPT | Power Block Option16 | 15 Amp, 1200V*** Block, 3 HP Cont.* | |
| 317-QADAMP-OPT | Power Block Option17 | 25 Amp, 1200V*** Block, 5 HP Cont.* | |
| 318-QADAMP-OPT | Power Block Option18 ** | 50 Amp, 1200V*** Block, 10 HP Cont.* | |
| 319-QADAMP-OPT | Power Block Option19 ** | 75 Amp, 1200V*** Block, 20 HP Cont.* | |
| 320-QADAMP-OPT | Power Block Option 20 ** | 100 Amp, 1200V*** Block, 30 HP. Cont. * | |

| Mounting Options | Item | Description | Note |
|------------------|---------------------------------|--|---|
| 303-QADAMP-OPT | External mounting opt Option 3 | Used with basic (Opt 1) Quad Amplifier, under 10 HP. Includes Fan and Shunt R. | For use when mounting HS external to cabinet |
| 3A3-QADAMP-OPT | External mounting opt Option 3A | Used with up-graded (Opt 2) Quad Amplifier over 10 HP. Same as above | Same as above. |
| 3B3-QADAMP-OPT | External mounting opt Option 3B | Does not include cooling fans or internal shunt resistor. | For use when mounting Amplifier HS in plenum. |
| 304-QADAMP-OPT | Internal mounting opt Option 4 | Used with basic (Opt 1) Quad Amplifier, under 10 HP. | Foot Mounting to cabinet panel |
| 3A4-QADAMP-OPT | Internal mounting opt Option 4A | Used with up-graded (Opt2) Quad Amplifier, over 10 HP. | Same as above. |

| Accessories | Item | Description | Note |
|--|-------------------------|---|--|
| 3A1-602582-100 | Circuit Breaker | 50 Amps 450 VAC 3 Phase | With external trip |
| 3A2-602582-100 | Circuit Breaker | 70 Amps 250 VAC 3 Phase | NA |
| 200-602739-024 | PWM Input Cables | 36" long cable with DB36 pin mini connectors at each end | Two required per Acc-8F. Connects between Quad Amplifier and Acc-8F |
| 3A0-602757-100 | External Shunt Resistor | 4.25 Ohms 1400 Watts each. 25" long 2" diameter Edge-Power resistor. Open Frame | Two required for 208/230 Quad Amplifier. Three required for 380/460 Quad Amplifier. Connected in series. |
| 3AO-602775-10X | ACC8F | Interface Circuit Board Used to connect Encoders to PMAC. | Two required per Quad Amplifier. Not required if PWM MACRO station is used. |
| <p>* When 30 HP is selected, only two additional axes may be used (three total, not four).</p> <p>** When a total of 7.5 HP or greater is selected, use Acc-4 (external shunt resistors).</p> <p>*** 600V/1200V indicates VDC rating of the igbt and has no connection to the main AC input (operating) voltage.</p> | | | |

GETTING STARTED

Receiving and Handling

Inspection upon Receipt

Upon the receipt of equipment, inspect all merchandise for any indication of damage that may have incurred during shipping and handling. If any items are damaged, do not accept them until the freight carrier makes an appropriate notation on the freight bill or express receipt. Claims for loss or damage in shipping must be taken up with the shipping or freight carrier.

Storage Requirements

Store the equipment in a clean environment until ready for installation. It is advisable to leave the equipment in its original shipping container until ready to use.

Prior to Installation

Each amplifier is carefully checked before shipping. However, upon receipt, make sure that the Quad Amplifier received corresponds to, or is properly rated for, the voltage and current of motors that are to be driven. The Quad Amplifier identification tag specifies the electrical ratings of each axis.

CAUTION:

It is important to double check the part number and serial number against the order form to avoid damage that may be caused by the misapplication of the digital Quad Amplifier.

Equipment Required

The Quad Amplifier is installed in conjunction with other Delta Tau Data System components to form a Quad Amplifier System. The following table identifies the equipment which, when installed and connected together, constitute a typical Quad Amplifier System. Figure 2 shows the interconnection of the Quad Amplifier System components.

| Component | Quantity | Description |
|---------------------|----------|--|
| Quad Amplifier | 1 | Delta Tau 4-Axis Digital Quad Amplifier |
| PMAC2 or PMAC2 Lite | 1 | Delta Tau 4-Axis Controller Card |
| Acc-8F | 1 - 2 | Delta Tau Digital Interface Board (one 16-inch cable is included with each Acc-8F to connect with the PMAC2) |
| Acc-8F, Opt 5 | 1 to 4 | 36-inch Delta Tau PWM input cables |
| Motors | 1 to 4 | Customer-supplied AC induction or brushless servo motors |

Installation Considerations and Options

The design of the Delta Tau Quad Amplifier allows for either internal chassis mounting or external chassis mounting. In either case, the unit can be mounted either horizontally or vertically. Vertically is the preferred mounting.

Option 3, 3A and 3B (External Mount)

Options 3, 3A and 3B are designed for external chassis mounting. These are used when the Quad Amplifier heat sink (cooling fans and internal shunt resistor included with Options 3 and 3A) is externally mounted through an electrical cabinet opening or when the Quad Amplifier heat sink is mounted in an air plenum (Option 3B) with external, customer supplied forced air and optional external shunt resistors (Acc 4).

Option 4 and 4A (Internal Mount)

Options 4 and 4A provide mounting feet and self-contained cooling fans. These are used when the Quad Amplifier is to be mounted to a panel, in a Hoffman style electrical box. Consider the following, before the Quad Amplifier is installed in a cabinet:

Heat Dissipation

The external mounting options (Opt3, Opt3A and Opt3B) allow the Quad Amplifier to be installed inside a cabinet, with the Quad Amplifier heat sink mounted external to the cabinet or in an air plenum. In the case of Opt 3B, provide good air circulation, in a plenum, with a minimum airflow across the heat sink of 70 CFM. Cooling should also be based on the whole system cabinet temperature not exceeding 45° C (113° F), as well as providing good airflow across the Quad Amplifier heat sink.

The internal mounting options (Opt4 and Opt4A) are self-contained, stand alone packages. They include cooling fans and a built-in shunt regulator, with internal shunt resistors for small motor loads of under 10 HP. To ensure long-term reliability, the ambient temperature of the cabinet should not exceed 45° C.

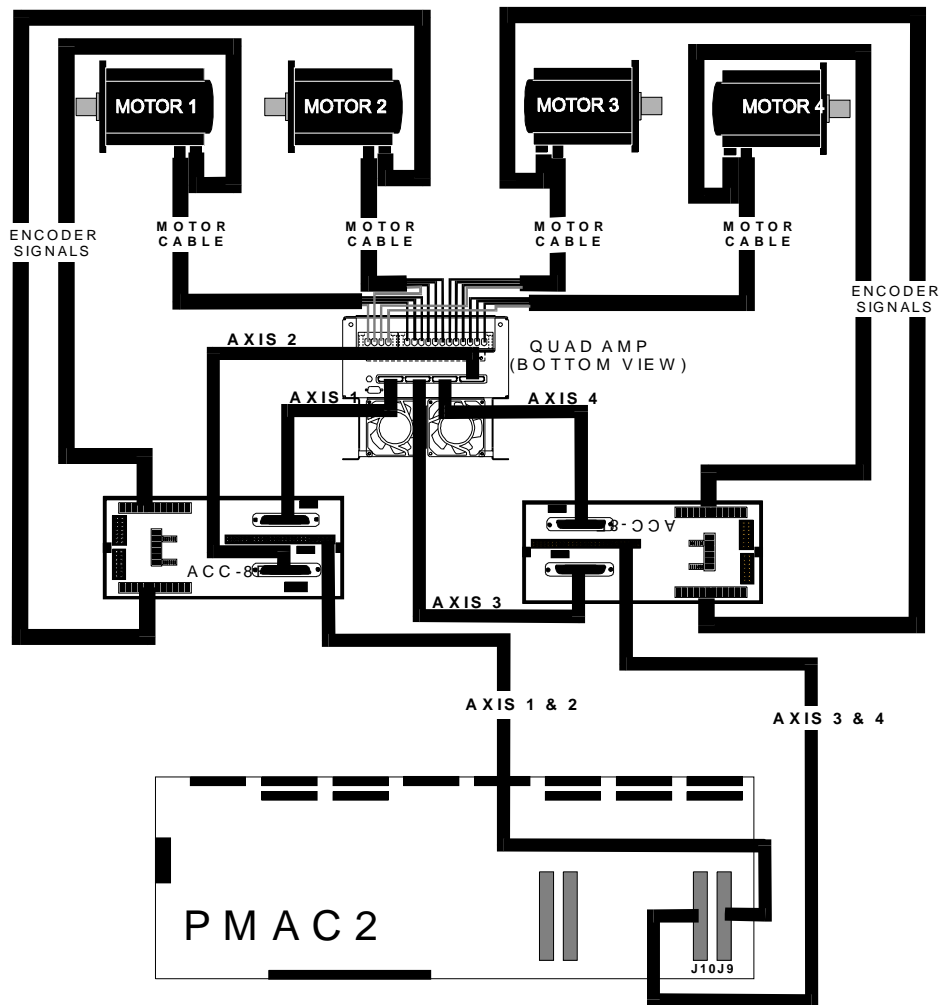

Figure 2 Quad Amplifier Interconnection Diagram

Multiple Units

When more than one Digital Quad Amplifier is installed in a limited area, such as an electrical box, always mount the amps side by side, and allow 3 inches (8 cm) between amplifiers. Do not stack the Quad Amplifiers.

Vibration

When the Quad Amplifier is installed near a source of excessive vibration install an isolation device underneath the Quad Amplifier.

THEORY OF OPERATION

Operation

The Quad Amplifier is a universal 4-axis 3-phase direct PWM drive which utilizes the latest in smart power technology from the world's leading vendors and the cutting edge algorithms of the new PMAC2 controller family. The Quad Amplifier is capable of driving all of the motor types commonly used in programmable motion control in both rotary and linear forms.

The Quad Amplifier is based on PWM (Pulse Width Modulation) which is a technique employing both frequency and phase to approximate sinusoidal currents and to control AC and DC motors.

Each axis of the Quad Amplifier uses a three H-bridge legs scheme. Each leg employs top and bottom IGBT transistor. The motor windings are connected between the center points of top and bottom pairs. When two appropriate IGBT transistors in the bridge are turned on, the current flows through any two motor windings. Any two (top and bottom) bridge transistors are turned on by a logic from PMAC2 with no other conditioning necessary, except an optical isolation. The Quad Amplifier performs no control functions itself; it simply accepts direct PWM commands from the PMAC2. PMAC2 requires the position feedback and the feedback about the current fed to the motors to commutate each controlled axis.

The current feedback is provided in digital form as a part of a serial data stream of 18-bits (12 bits report the current feedback and remaining 6-bits report fault conditions) from the current feedback A/D converters which are located in the Quad Amplifier. Each axis has its own mask word that tells the PMAC2 how many bits to expect from the A/D converter. The clock and the strobe for the digital feedback are programmable at the PMAC2.

The position feedback in the form of quadrature A, B and C and/or ChU, ChV, ChW and ChT generally is fed to PMAC2 via Acc-8F. The position feedback is not connected to the Quad Amplifier in any way.

Configuration

The Quad Amplifier consists of the following:

- One main logic board (I/O)
- One 4-axis current sense board
- One firing board for each IGBT power device. One for each axis, four axes maximum.
- One soft start and shunt regulator board
- One DC bus power supply

Logic Board

The Logic Board (I/O) acts as link to PMAC2 (via Acc-8F) and has several functions (All signals arrive/and leave the logic board through a separate mini DB36 connector for each axis):

1. Differential PWM signals are opto-isolated and sent directly to the firing boards.
2. All the control signals for the current sense board are transmitted to the current sense board via a flat 60-pin cable. The digitized current feedback is routed back from the current sense board via the same cable and is passed to PMAC2 through a mini-D36 connector.
3. The Logic Board processes Amp Enable and Amp Fault signals for all four axes. The Amp Enable is a differential pair and a separate line is supplied from PMAC2 for each axis. The default polarity of Amp Enable is positive true. A high on AENA+ and a low on AENA- will enable the Quad Amplifier. In the event of a failure, the Quad Amplifier will drive the Amp Fault line positive true and send the fault signal to PMAC2.
4. It provides protection against various Quad Amplifier fault conditions and it displays a condition of the Quad Amplifier via an LED Fault Indicator on the Current Sense board (see Fault Detection and Fault Codes section in this manual).

Current Sense Board

The Current Sense Board has eight Hall Effect (LEM) modules for current sense and eight on-board A/D converters that transform four channels of motor current to digital form. Each channel provides information on two phases (A phase and B phase). The third phase is mathematically created in the PMAC2.

Firing Boards

The firing boards receive their signals directly from the PMAC2 through the Logic board differential receivers and turn appropriate top and bottom IGBT on to allow current flow through a motor phase (winding). The PWM signals are opto-isolated before they reach the IGBT firing pins. The firing pulses for each IGBT transistor are differential to increase noise immunity. To avoid ground loops and accidental IGBT turn-on, each firing board is equipped with an isolated power supply.

Soft Start and Shunt Regulator

The Soft Start and Shunt Regulator circuit board's function is to provide soft charge and shunt regulation for the Quad Amplifier. It consists of a main board (602800-1) and a dual split gate drive power supply piggy board (602801-1) that mounts on the main board with plastic screws and standoffs.

The Soft Start and Shunt Regulator Main and Shunt set points (when main IGBT and shunt IGBT turn on) are set as a percentage of the nominal bus voltage for the actual AC line voltage. Therefore, set points move automatically with the line voltage. This allows operation at any line voltage above 30 VAC and prevents shunt damage under high line conditions. A condition above 250/500 VAC will cause a high line fault, which will prevent operation of the Quad Amplifier. Over voltage is set at 410/820 VDC and can be factory set lower with R2.

If there is an absence of logic power (+/- 15V), the split gate drive power supply will not be able to power the K1 relay and bus voltage is prevented from coming up because the main and soft start IGBT gates and emitters are shorted via the K1 relay (NC) contacts.

Soft Start

If there is no 3-phase line voltage (VAC) present, a No Line fault condition prevents momentary main operation on power-up before line sense levels are up. Once 3-phase line voltage is applied, the No Line fault is cleared by a clear fault pulse, which comes from Quad Amplifier logic board upon issuing an Enable command. When Enable is issued, the Soft Start IGBT will turn on and charge the bus capacitors via Soft Start resistor (100 Ohm, 50 Watts). After the bus capacitors are charged to 80% of the nominal bus voltage for the AC line, the main IGBT will turn on, bypassing the Soft Start resistor.

Shunt Regulator

When the bus voltage rises to 114 % of the nominal bus voltage for the AC line due to a deceleration of a motor, the shunt IGBT turns on and connects the shunt resistor across the bus until the bus voltage drops to normal. The value of 114% was selected so that even at 250 VAC (about 353 VDC bus) the shunt regulator will turn on at approximately 400 VDC before the over voltage (410VDC) trips.

DC Bus Power Supply

The AC Input voltage from L1, L2, and L3 is rectified into a DC bus voltage. The DC Bus Power Supply consists of a three-phase rectifier bridge and an IGBT switch. The 208/230 VAC amplifier has a 15 k Ohm bleeding resistor and six 1,800 μ F filter capacitors, connected in parallel. The 380/460V Quad Amplifier utilizes a serial/parallel configuration of six filter capacitors and two 15 k Ohm bleeder resistors in series across + Bus and - Bus.

Heat Dissipation

The capability of the Quad Amplifier and the IGBT modules is based upon the heat they can dissipate; the more quickly heat can be removed from the IGBT module, the more current it can handle. Heat is created whenever an IGBT is turned on or off. These transitions are called switching losses. Whenever current is flowing, the switching losses represent a sizable and unavoidable part of the heat generated by the Quad Amplifier. Since the switching losses occur on transitions and the transitions are a function of frequency, a lower PWM frequency can mean a cooler amplifier capable of more power and a higher PWM frequency will result in more heat and less overall deliverable power to the motor.

Of course, simply lowering the PWM frequency will not produce optimal results on all motors. Low inductance motors, for instance, require a higher frequency. In addition, high frequency PWM can reduce velocity ripple on small motors. The choice of a PWM frequency is application dependent and entirely programmable on the Delta Tau Digital Amplifier. Similarly, this facility must be taken into consideration when choosing a power rating for your application.

Shunt Considerations

CAUTION:

The Quad Amplifier has an internal shunt regulator with dumping resistors. These are not sized for a particular load and may not be adequate for any particular application. These internal shunt resistors are nominally capable of dumping 25 amps at low duty cycle (<25%). If the application has a high duty cycle or requires more shunt dumping, an external shunt resistor will be necessary.

Depending upon the application, a shunt regulator is often necessary to dissipate the energy regenerated into the DC bus by the stored kinetic energy of the motor and reflected load, during deceleration. The components in the amplifier are rated for 410VDC/820VDC respectively. When the motor with load decelerates, it can act as a generator, pumping current back into the DC bus instead of from it, thereby raising the bus DC voltage. This problem is magnified for large spindle or high inertia applications that must be brought to a halt in a very short time. Care must be taken to see that DC bus voltage does not exceed 410VDC/820VDC. If DC bus voltage exceeds 410VDC/820VDC, nuisance over voltage may occur and the amplifier could be damaged.

To prevent this, the shunt should be able to draw as much current from the DC bus as the motors are capable of putting into it. The faster the motors are decelerated the greater the current. A spindle motor using 60 amps continuously will require a shunt that can dump at least that much current. Refer to the Delta Tau Soft Start and Shunt Resistor circuit board section of this manual for more information.

INSTALLATION

Wiring the Quad Amplifier System

Quad Amplifier Channel Connections

The Quad Amplifier channels must be connected in a particular order for proper operation. It is essential that the timing of all signals associated with the Quad Amplifier logic board shares the ADC converter clocks for Quad v channels 1-2 and channels 3-4. The ADC clocks are generated from the gate array associated with the axis channel on the PMAC. Each PMAC Gate Array controls four axis channels. Therefore, make sure to connect Quad Amplifier channels 1 and 2 or channels 3 and 4 to the same PMAC channels associated with the same ADC clock Gate array. Faulty operation or even amplifier failure may occur if the user mixes Gate Array channels on either Quad Amplifier channels 1-2 or 3-4. The following chart lists the possible combinations for proper Quad Amplifier operation.

Two Quad Amplifier Example

| PMAC Axes | Quad AMP 1 Channels 1-2 | Quad AMP 1 Channels 3-4 | Quad AMP 2 Channels 1-2 | Quad AMP 2 Channels 3-4 |
|-----------------|----------------------------|----------------------------|----------------------------|----------------------------|
| Configuration 1 | A | A | B | B |
| Configuration 2 | A | B | A | B |
| Configuration 3 | A | B | B | A |
| Configuration 4 | B | A | B | A |
| Configuration 5 | B | A | A | B |
| Configuration 6 | B | B | A | A |

(A) Can have the following PMAC Axis configuration (GATE 0)

- 1-2 or 3-4
- 1-3 or 2-4
- 1-4 or 2-3

(B) Can have the following PMAC Axis configuration (GATE 1)

- 5-6 or 7-8
- 5-7 or 6-8
- 5-8 or 6-7

Typical Quad Amplifier Setup

A typical Quad Amplifier setup would have all the PMAC axes associated with the corresponding Quad Amplifier channels. For this example, PMAC axes 1, 2, 3 and 4 are connected to the first Quad Amplifier and axes 5, 6, 7, and 8 are connected to the second first Quad Amplifier.

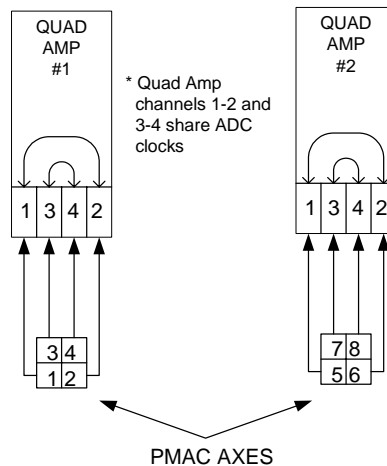

Figure 3

Non-Standard Quad Amplifier Setup

This example shows the Quad Amplifier setup with PMAC axes 1, 2, 7, and 8 are connected to first Quad Amplifier #1 and PMAC Axes 3, 4, 5 and 6 are connected to first Quad Amplifier #2. Since first Quad Amplifier channels 1-2 and 3-4 share ADC clock signals, the PMAC channels connected to these amplifier channels must be generated at the same Gate Array.

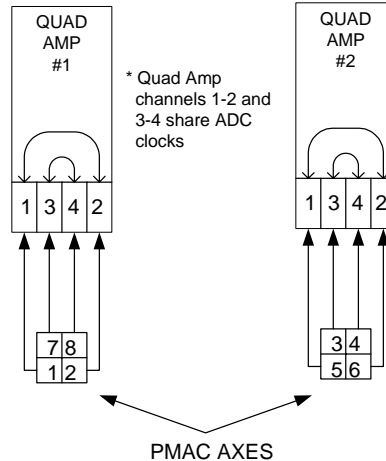

Figure 4

Accessory Terminal Board (Acc-8F, Acc-24E2)

Each Quad Amplifier requires one or two Acc-8F accessory terminal boards to interface to the PMAC2. The Acc-8F boards provide easy and straightforward connections between the Quad Amplifier and the PMAC2, as well as to the encoders. The cables required to connect the Acc-8F to the PMAC2 PC are provided with each Acc-8F. Refer to the PMAC2 Acc-8F User Manual.

PWM Input Cables

36-inch PWM input cables (Acc-8F, Opt 5) are available from Delta Tau Data Systems, Inc. One cable is required for each PWM axis.

Connectors

All Quad Amplifier connectors are identified in Figures 5 and 6. The signal connections between PMAC2 and Acc-8F are marked as Axis 1 through Axis 4 on the first Quad Amplifier bottom panel. The detailed pin-outs and signals between the Acc-8F and the first Quad Amplifier are shown in the table following Figure 6.

Connecting Power Devices

Warning:

Read this section carefully before attempting to wire the connectors or apply main power to the first Quad Amplifier.

Figure 5 is a typical wiring schematic showing the main power circuits and Figure 6 is an example of how to connect the first Quad Amplifier to the peripheral power devices. Delta Tau recommends the use of the following power and safety devices to ensure long amplifier life and reliability.

- Circuit Breaker
- Line Filter
- Magnetic Contactor

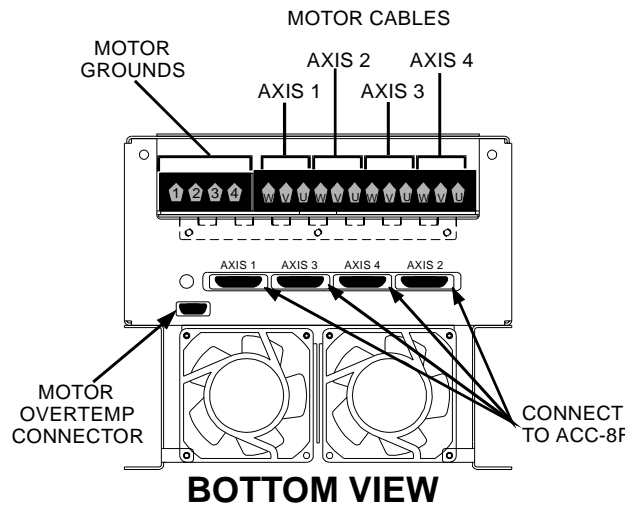
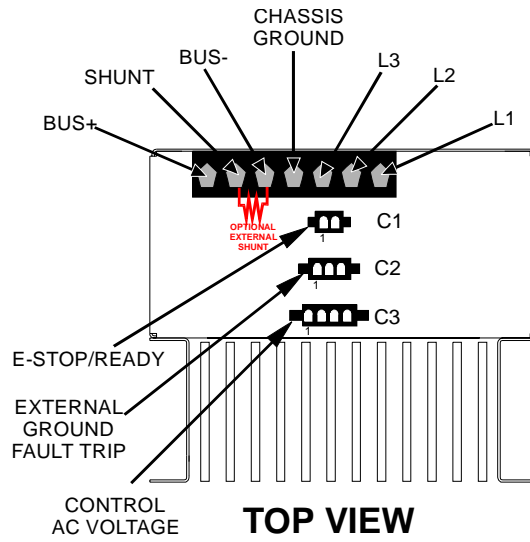

Figure 5 and 6 Quad Amplifier Connector Locations

| Pin# | Symbol | Function | Description | Notes |
|------|------------|----------|------------------------|---------------------|
| 1 | Fc A1 | Input | | |
| 2 | Fc C1 | Input | | |
| 3 | Clk0+ | Input | A/D Convert Clock | |
| 4 | Convert0+ | Input | A/D Convert Strobe | |
| 5 | Atddaa1+ | Output | Chan A ADC Serial Data | |
| 6 | Atddab1+ | Output | Chan B ADC Serial Data | |
| 7 | Aena1+ | Input | Amp Enable | Positive Enable |
| 8 | Fault1+ | Output | Amp Fault | Negative True Fault |
| 9 | Pwmatop1+ | Input | Phase A Top CMD | |
| 10 | Pwmabot1+ | Input | Phase A Bottom CMD | |
| 11 | Pwmbtop1+ | Input | Phase B Top CMD | |
| 12 | Pwmbbot1+ | Input | Phase B Bottom CMD | |
| 13 | Pwmcotop1+ | Input | Phase C Top CMD | |
| 14 | Pwmcobot1+ | Input | Phase C Bottom CMD | |
| 15 | Gnd | Common | Reference Voltage | |
| 16 | Pmac +5 | Input | +5V Power | |
| 17 | NC | | | |
| 18 | NC | | | |
| 19 | Fc B1 | Input | | |
| 20 | Fc D1 | Input | | |
| 21 | Clk0- | Input | A/D Convert Clock | |
| 22 | Convert0- | Input | A/D Convert Strobe | |
| 23 | Atddaa1- | Output | Chan A ADC Serial Data | |
| 24 | Atddab1- | Output | Chan B ADC Serial Data | |
| 25 | Aena1- | Input | Amp Enable | |
| 26 | Fault1- | Output | Amplifier Fault | |
| 27 | Pwmatop1- | Input | Phase A Top CMD | |
| 28 | Pwmabot1- | Input | Phase A Bottom CMD | |
| 29 | Pwmbtop1- | Input | Phase B Top CMD | |
| 30 | Pwmbbot1- | Input | Phase B Bottom CMD | |
| 31 | Pwmcotop1- | Input | Phase B Top CMD | |
| 32 | Pwmcobot1- | Input | Phase C Bottom CMD | |
| 33 | Gnd | Common | Reference Voltage | |
| 34 | (X)Pmac_+5 | Input | +5V Power | |
| 35 | NC | | | |
| 36 | NC | | | |

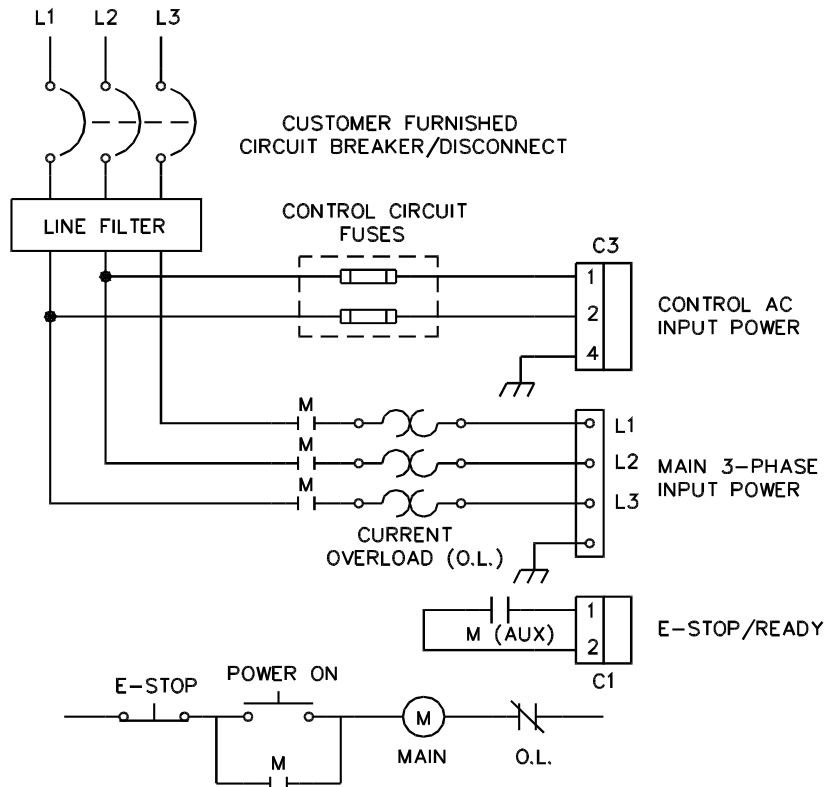

Figure 7 Quad Amp Main Circuit Wiring Diagram

Main AC Input Power

Connect desired main input power to input terminals marked L1, L2, and L3 (see Figure 7). The power ground can be connected at the terminal marked CHAS GND or at the grounding screw, marked E, located on the end panel of the Quad Amplifier chassis. The main input power terminals are rated for 600V and 85 Amps.

Control AC Input Voltage

Connect single-phase input power to pins 1 and 2 of AC input connector C3 marked CONTROL AC INPUT PWR, located on the top panel of the Quad Amplifier (see Figure 7). Pin 4 of connector C3 is used for ground (green wire). If the input power requirements have changed since the Quad Amplifier order, the Control Power Transformer (T201), located under the Quad Amplifier cover, must be reconfigured for proper operation (see Figures 7 and 8).

Note:

Control AC Input voltage is factory set in accordance with the ordering information.

For 120VAC Operation

Jump pin 1 to pin 5 and jump pin 2 to pin 6. Power is applied to pins 1 and 2 via AC input connector C3.

For 208VAC Operation

Jump pin 1 to pin 5 and jump pin 3 to pin 7. Power is applied to pins 1 and 3 via AC input connector C3.

For 230VAC Operation

Jump pin 1 to pin 5 and jump pin 4 to pin 8. Power is applied to pins 1 and 4 via AC input connector C3.

For 380 VAC Operation

Jump pin 4 to pin 5 and pin 6 to pin 9. Power is applied to pins 1 and 10 via AC input connector C3.

For 460 VAC Operation

Jump pin 4 to pin 5. Power is applied to pins 1 and 8 via AC input connector C3.

For 480 VAC Operation

Jump pin 4 to pin 5 and pin 8 to pin 9. Power is applied to pins 1 and 10 via AC input connector C3.

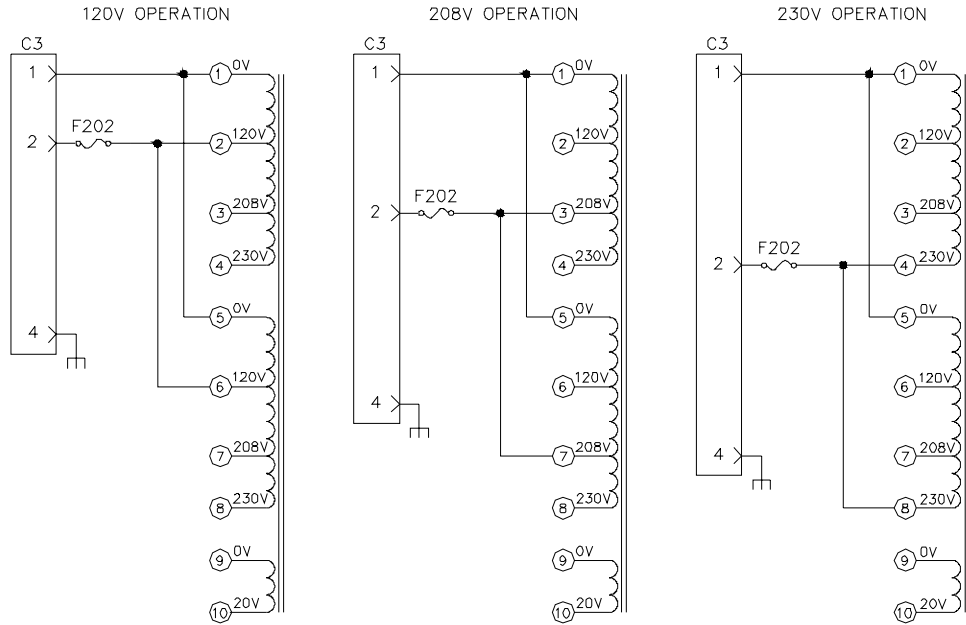

Figure 8 120V/208V/230V Quad Amplifier Transformer T201 Schematic Diagram

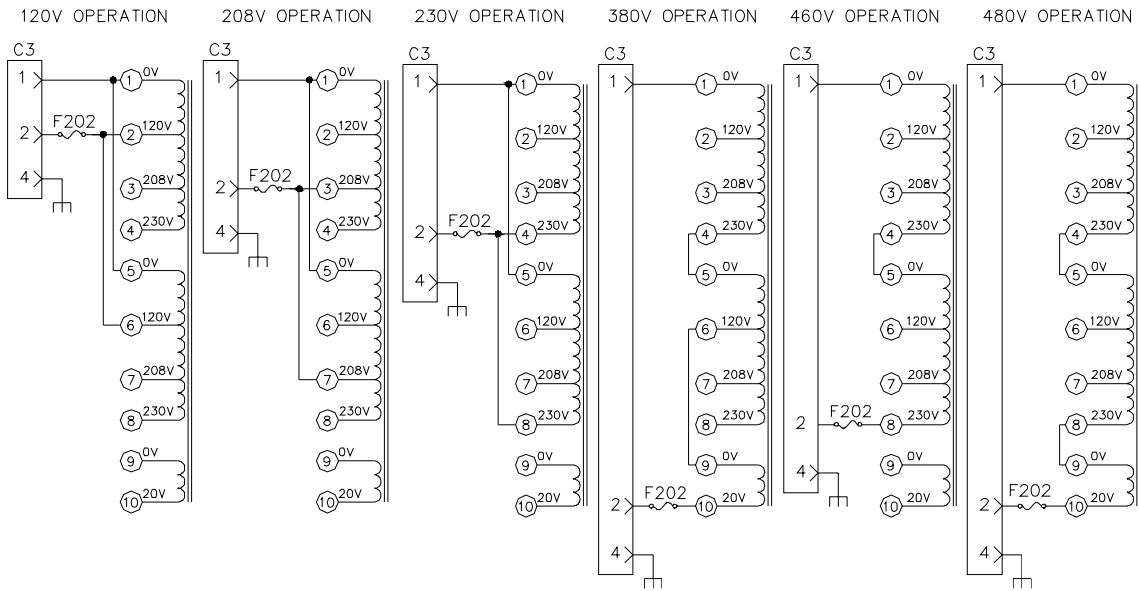

Figure 9 380V/460V/480V Quad Amplifier Transformer T201 Schematic Diagram

Bus Power Enable/Emergency Stop

CAUTION:

Any wiring should be attempted only after the drive has been isolated from the main AC supply and 10 to 12 minutes has elapsed to allow the internal bus capacitors to discharge.

The normally open (NO) Main AC Contactor auxiliary contacts must be wired and connected to Connector C1 pins 1 and 2, otherwise the Quad Amplifier will not power up. Connector C1 is located on the top of the Quad Amplifier (See Figure 9)

Shunt and Bus

Resistor terminals are provided so that the user can connect an external shunt resistor to the Quad Amplifier (See Figure 10). The shunt resistors should be a resistive (non-inductive) load of appropriate power and voltage rating for the bus and the regenerative load. External shunt resistors are available from Delta Tau as Quad Amplifier Acc-4. These resistors (two 4.25 ohm, 1400W resistors for 230 VAC operation and three 4.25 ohm, 1400W resistors for 380/460 VAC operation), when connected in series (8.5 ohms total), will dump over 45 amps.

Bus

Along with the BUS- terminal, these terminals may be used to power external servo amplifiers. Consult Delta Tau Data Systems Technical Assistance for information concerning external servo amplifiers. .

Bus Filter/Indicator

The bus filter/indicator board is mounted to the Bus+ and Bus- power bars, which are located between Axis 1 and 3 and Axis 2 and 4 output blocks inside of the Quad Amplifier. The bus filter/indicator board is equipped with a neon light that illuminates when bus voltage is present. If the Main AC Power is turned off, the neon light will stay lit until the bus voltage discharges to about 80 VDC.

Motor Wiring

The motor cable wire gauge for each axis must be sized to handle the continuous output current of the axis to which it is connected.

Motor Over-Temp Sensor

The output pins of the 9-pin DIN connector, located on the end panel of the Quad Amplifier, must be connected to the motor over-temp switches. If this connector is not connected to the motor over-temp switches, it must be jumpered with a Delta Tau supplied termination connector for normal Quad Amplifier operation.

Jumpers, Potentiometers, Test Points, and LEDs

There are configurable jumpers, potentiometers, test points, and LEDs on the circuit boards inside the Quad Amplifier. The jumpers are factory set to each customer's specifications and usually do not need to be changed. Figures 10 through 12 show the locations of these jumpers, potentiometers, test points, and LEDs. The following tables list the default jumper settings, the Soft Start board potentiometer factory settings and test point voltages, describe the LED indications for each board.

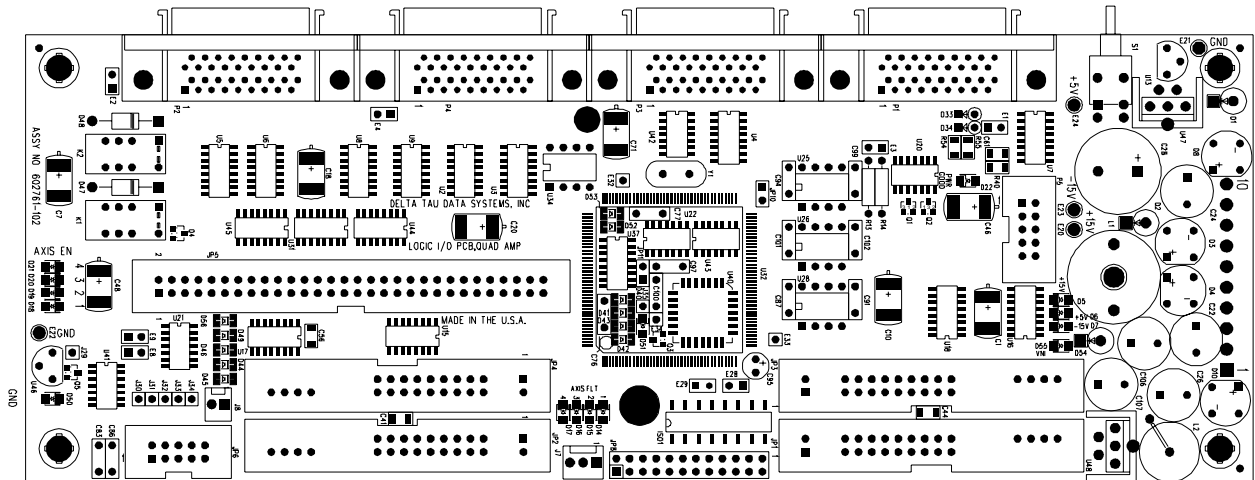

Figure 10 Logic I/O Board Jumper and LED Locations

| Name | Position | Description | Default |
|-------|----------|-----------------------------------|---------|
| E1-E4 | IN | Shield To Local Ground | Open |
| | OUT | | |
| E7 | IN | Do Not Use | Open |
| | OUT | | |
| E8 | IN | Enable Shunt Transistor In Module | Open |
| | OUT | | |
| E9 | IN | Enable Shunt Transistor In Module | Open |
| | OUT | | |
| E10 | IN | Do Not Use | Open |
| | OUT | | |
| E28 | IN | Do Not Use | Open |
| | OUT | | |
| E29 | IN | Do Not Use | Open |
| | OUT | | |
| E30 | IN | Do Not Use | Open |
| | OUT | | |

| LED | Symbol | Description |
|-----|------------|---|
| D5 | + 15 V | On when + 15VDC logic power is present |
| D6 | + 5 V | On when + 5 VDC logic power is present |
| D7 | - 15 V | On when - 15 VDC logic power is present |
| D14 | AXIS 1 FLT | On when Axis #1 faulted |
| D15 | AXIS 2 FLT | On when Axis #2 faulted |
| D16 | AXIS 3 FLT | On when Axis #3 faulted |
| D17 | AXIS 4 FLT | On when Axis #4 faulted |
| D18 | AXIS 1 EN | On when Axis #1 is enabled |
| D19 | AXIS 2 EN | On when Axis #2 is enabled |
| D20 | AXIS 3 EN | On when Axis #3 is enabled |
| D21 | AXIS 4 EN | On when Axis #4 is enabled |
| D22 | PWR GOOD | On when all logic powers are at the proper level |
| D50 | GOT ENABLE | On when any AXIS ENABLE signal is received at the Logic PCB |
| D55 | VNI | On when + 15 VDC logic power for output IGBTs is present |

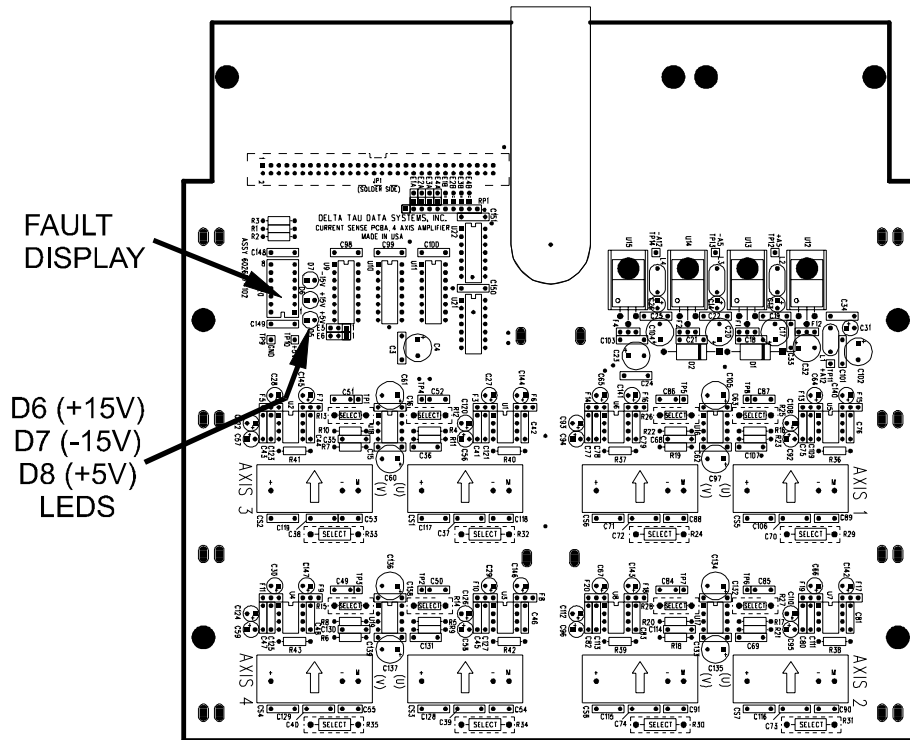

Figure 11 Current Sense Board Jumper and LED Locations

| Name | Position | Description | Default |
|---------|----------|-----------------------------------|------------------|
| E1A-E4A | IN | Enable Serial Fault Data, Phase A | Open |
| | OUT | | |
| E1B-E4B | IN | Enable Serial Fault Data, Phase B | Open |
| | OUT | | |
| E5 | IN | Clock Polarity | 2 and 3 Jumpered |
| | OUT | | |
| E6 | IN | Convert Polarity | 2 and 3 Jumpered |
| | OUT | | |

| LED | Symbol | Description |
|-----|--------|--|
| D5 | + 5 V | On when + 5Vdc logic power is present |
| D6 | + 15 V | On when + 15Vdc logic power is present |
| D7 | - 15 V | On when - 15Vdc logic power is present |

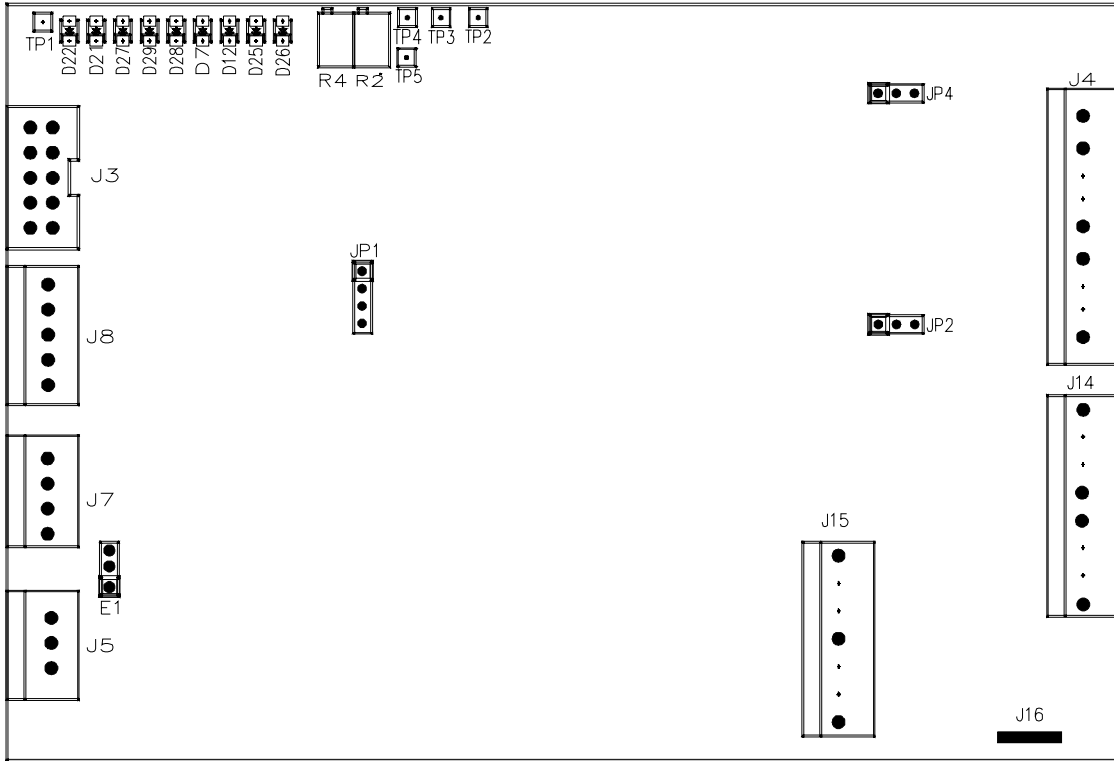

Figure 62 Soft Start Board Jumper, Potentiometer, Test Point, and LED Locations

| Name | Position | Description | Default |
|------|------------|----------------------------------|---------|
| E1 | 1-2 jumper | Internal Power Supply Connection | |
| | 2-3 open | | |
| JP6 | Jumper | E-Stop Configuration | |
| JP7 | Jumper | E-Stop Configuration | |

| Symbol | Description | Tp Factory Set | Notes |
|----------|------------------------------|----------------|--|
| R4 & TP5 | High line fault set point | 5.2/10.4 V | High line trips at 255/510 VAC |
| R2 & TP4 | Over voltage fault set point | 4.1/8.2 V | O/V trips at 410/820 VDC |
| TP3 | Shunt IGBT turn-on set point | 3.7V @ 230 VAC | Shunt turns on at 114% of the nominal bus voltage |
| TP2 | Main IGBT turn-on set point | 2.75V @ 230VAC | Main IGBT turns on at 80% of the nominal bus voltage |

Note: Main and shunt set points are line sensitive and will vary with line voltage.

| LED | Symbol | Description |
|-----|--------|--|
| D25 | L/LOW | Low Line, on when line voltage is below 30 VAC |
| D12 | L/HI | High Line, on when line voltage is above 255 VAC |
| D7 | GND | GND Fault, on if GND fault detected by Quad Amplifier logic board |
| D29 | BIAS | Gate drive/bias fault, on if the gate drive supply fails |
| D27 | OPEN | Open contacts fault, on when no main AC contactor auxiliary contacts are not wired to QA or not working properly |
| D21 | SHNT | Shunt, on when the shunt regulator is on |
| D22 | RDY | Ready, on when no fault condition |
| D26 | NOLINE | No Line, on when no 3-phase line present |
| D28 | DSAT | De-saturation fault, on when current surge across the main IGBT or Shunt IGBT is detected |

Grounding

General

It is important to follow some precautions to avoid ground loops or unwanted electrical noise disturbances.

- All signal cables must be shielded.
- Two or more power wires in the same sleeve must be twisted and shielded.
- A shield that does not carry current can be connected at both ends
- A cable with low power electrical signals should never run in the same proximity of high power cables.

Main Power Supply (DC Bus)

The Quad Amplifier chassis must be connected to earth (ground). A ground screw, designated E on the Quad Amplifier, has been provided for this and is located on the top panel of the amplifier.

Motor

Each motor housing must be connected to Chassis Ground. A Chassis Ground terminal is provided for each motor at the motor output terminal block. Motor leads should be shielded to help avoid stray electrical noise and electrical radiation.

PMAC2 I-Variables Setup

Reference the PMAC2 Family Addendum to the PMAC User Manual and Software Reference for information on how to set up all the I-variables and other necessary parameters. The preferred method for tuning the amplifier is to use the P2 Setup software package available from Delta Tau. There are several PMAC2 I-variables we emphasize for proper operation of the Quad Amplifier.

Ix00

This parameter determines whether a motor is active (Ix00=1) or inactive (Ix00=0). An active motor may be enabled (either in open or closed loop) or disabled, depending on commands or events.

Ix01

Must be set to 1 to enable commutation for any motor connected to the Quad Amplifier.

Ix02

Must contain the address of the A output register for the machine interface channel n used to connect to the amplifier. Usually, channel number n equals motor number x. The default values of Ix02 are valid when n = x.

Ix25

Must contain the address of the flag register for the machine interface channel n used to connect to the Amplifier. The same interface channel number must be used for the flags and the command outputs! Default values for Ix25 are valid when n = x.

Ix82

Must contain the address of the B current feedback register for the machine interface channel n used to connect to the amplifier. Usually, channel number n equals motor number x. The default values of Ix82 are valid when n = x.

I900

I900 controls the maximum phase clock frequency for PMAC2 and the PWM frequency for machine interface channels 1-4. Refer to PMAC2 Family Addendum to User Manual and Software Reference for further information. If I900 is accidentally set above approximately 15 kHz, the Quad Amplifier will disable all enabled axes and the LED display will show a code 9.

Note:

The Quad Amplifier has a built-in protection against accidentally setting I900 (PWM frequency) too high, and exceeding the PWM input frequency rating of the power blocks.

I9n6

For machine interface channel n, I9n6 must be set to 0 to select PWM output format. If i9n6 is set to 1 or 3 while a 'n' axis is enabled, Quad Amplifier will disable all enabled axes and the LED display will show code 'A'. Also, if i9n6 is set to 1 or 3 and then an 'n' axis is enabled, all enabled axes will disable and the LED display will show 'A' as well. I9n6 is a variable specific to an axis, but because of its importance, Quad Amplifier fault circuits treat it as a global variable. Therefore, if a user assigns an M-variables to PMAC2 Gate Array registers x:\$0710,8,4 through x:\$0713,8,4 to monitor Quad Amplifier condition, and sets i9n6 accidentally to 1 or 3 and then enables 'n' axis, all M variables will report a fault code 'A'.

Note:

The Quad Amplifier has a built-in protection against accidentally setting I9n6 (Output select mode) to DAC mode (I9n6=1 or I9n6=3).

Start-Up Procedures

Before the main power is applied to the Quad Amplifier, check the following:

1. Verify the AC line voltage is corrected for the model of Quad Amplifier being used.
2. Check that motors and encoders are properly wired and grounded.
3. Ensure the PMAC2 I-variables are set as described above.

Power On Sequence

1. Ensure E-Stop Plug (C1) is wired to the normally open auxiliary switch of the Main AC Power Contactor.
2. Energize the circuit breaker/disconnect to apply power.
3. Energize Main contactor. LED fault indicator should display E at this point. Issue a <00> from the terminal window of PEWIN or P2 Setup. LED Fault indicator display should change to C. Allow 1 to 2 seconds for the Quad Amplifier Soft Start circuit to charge the DC bus capacitors.
4. Issuing another <00> command will enable the appropriate axis and the LED fault indicator will show 0.0 (everything OK, axis enabled). The Quad Amplifier is now ready for use.
5. Set up PMAC2 for digital current loop control of the Quad Amplifier and a motor using the P-2 Setup program. Save the PMAC2 configuration.

P2Setup

The P2Setup program is essential for making the Quad Amplifier work with PMAC. The user should not attempt to use the Quad Amplifier without P2Setup.

P2Setup Functions

P2Setup performs the following functions:

- Tests current sensors and ensures they are in proper working condition.
- Tests encoder and ensures proper commutation feedback is available.
- Tunes the current loop to the desired performance parameters.
- Phases the motor for servomotors, magnetization current, and slip gain tuning for induction motors.
- Calculates PMAC2 current protection parameters for Quad Amplifier and motors (reference Table 4-9).
- Tunes the position and velocity loop.

During this tuning process, P2Setup also determines the commutation parameters and commands the PMAC appropriately.

| Power Block Option | Continuous Hp | Continuous Current (A) | Peak Current 2 Sec (A) | Max ADC Value |
|--|---------------|------------------------|------------------------|---------------|
| 208/230 VAC | | | | |
| 5 | 0.75 | 2 | 5 | 6.25 |
| 6 | 1.5 | 4 | 11 | 13.75 |
| 7 | 2 | 5 | 15 | 18.75 |
| 8 | 3 | 7 | 21 | 26.25 |
| 9 | 5 | 15 | 36 | 45 |
| 10 | 7.5 | 20 | 54 | 67.5 |
| 11 | 10 | 25 | 75 | 93.75 |
| 12 | 15 | 35 | 100 | 125 |
| 13 | 20 | 50 | 150 | 187.5 |
| 14 | 30 | 75 | 200 | 250 |
| 380/460 VAC | | | | |
| 15 | 2 | 2.5 | 7.5 | 9.375 |
| 16 | 3 | 3.5 | 10.5 | 13.125 |
| 17 | 5 | 6 | 18 | 22.5 |
| 18 | 10 | 12.5 | 40 | 50 |
| 19 | 20 | 25 | 75 | 93.75 |
| 20 | 30 | 35 | 100 | 125 |
| Enter Max ADC value in P2-Setup, step Current Protection. Enter Peak Current and Continuous Current values, if applicable. | | | | |

F.A.Q

1. **PWM Frequency** – The default value suggested by P2Setup (4.5 kHz) works well for most applications. If more heat is generated in the motor than the amplifier, using a higher PWM frequency may assuage this problem.

- a. **Set up a Lower Voltage Motor with the Quad Amplifier.** The following steps should be followed in P2Setup to ensure that the appropriate voltage is used for the motor while using the Quad Amplifier:

After PWM frequency and Phase and Servo frequencies have been set up successfully, click the Terminal Window tab.

Modify Ix66 using the following formula:

$$Ix66 = \frac{1900 * Motor_peak_voltage}{Quad_Amp_Bus_Voltage}$$

TROUBLESHOOTING

Logic Fault Detection and Fault Codes

The Quad Amplifier is capable of detecting and reporting a variety of fault conditions. These conditions are broken into two types: axis-specific and global.

Axis-Specific Faults

This type of fault is related to one axis only and typically is not something that would prevent the amplifier as a whole from continuing to operate. These faults are specific to the modules or motors and involve temperature (module or motor), low level ground fault, and over or under current. These faults only disable the axis involved (when they occur and remain active), preventing the axis from being enabled until they actually disappear.

Global Faults

The second type of fault concerns elements critical to the entire amplifier. These faults include heat-sink over-temperature, general power supply faults, bus over-voltage etc. These faults are transient and are latched in the Xilinx gate. The entire amplifier is disabled and remains so, with the fault displayed, until the controller attempts to re-enable it. If the cause of the fault has been remedied, the fault is cleared from the display and PWM is sent to the IGBT modules. If the cause of the fault has not been removed, the amplifier will fault again and disable.

Fault Reporting

Fault conditions are reported in two places. First, the on-board (current sense board) LED displays the fault code as a hexadecimal digit. Second, the fault code is attached to the end of the serial A/D converter data stream being sent to PMAC2 on the A channel of each axis. There is also a fault LED associated with each axis that will illuminate in the case of a fault on the associated axis.

Serial Fault/Status Data

The fault/status circuitry will add six bits to the serial data stream following the twelve bits of serial A/D converter data. The first four bits is the 4-bit fault code; the fifth bit is reserved for the future and sixth bit is the shunt active status bit. The 4-bit fault code sent back to PMAC2 for each axis could reflect either global faults or axis-specific faults on that axis. It will not reflect an axis-specific fault from another axis. If there is an axis-specific fault and a global fault, the code of the axis with the fault will show the global fault (due to the rule of the higher fault number being reported).

The fault code is accessed in PMAC2 memory via M-variables. For example, the RAM register location X:\$0710 contains Channel 1 ADC1A input image value. Assign M130->x:\$0710,8,4 to access 4-bit values only, to read the fault code for channel #1. The following is an example of a PLC that would continuously scan for a Bus under voltage condition.

```
Close
Delete Gather
M130->x:$0710,8,4
;
Open plc 1
Clear
  If (M105=12)
    Send "Bus under voltage fault"
  Dis plc 1
Endif
Close
```

Note:

Jumpers E1A, E1B, E2A, E2B, E3A, E3B, E4A, E4B must be installed on the current sense board so that the 4-bit fault code can be accessed at PMAC2 Gate Array Registers.

Once such a condition occurs, the PLC notifies the user with an on-screen message and then disables itself. Note that C is a hex fault code for Bus under voltage and its decimal representation is 12.

LED Fault Indicator

The fault information is reported as a 4-bit value (0-15 decimal, 0-F hex). A value of 0 indicates no fault. A value greater than 0 specifies a fault and the number indicates which fault.

Global faults are numbered in the range 8-F (hex). Axis-specific fault codes are numbered in the range 1-7 (hex). In the case of multiple faults, the higher-numbered fault condition is reported.

If there is no fault condition, the display will indicate a 0. With a 0 in the display, the left decimal point shall be lit if any of the axes is enabled. The right decimal point shall be lit if the internal shunt is active.

The LED fault indicator will provide a following common fault code for the Quad Amplifier:

| | |
|----------|---------------------------------------|
| 0 | Everything O.K. |
| 1 | General firing module fault |
| 2 | Module over temperature |
| 3 | Ground fault |
| 4 | Over current (surge) fault |
| 5 | Motor over temperature |
| 6 | TBD |
| 7 | TBD |
| 8 | Heat-sink over temperature fault |
| 9 | High PWM frequency fault |
| A | DAC (nonPWM) fault |
| B | Bus over voltage |
| C | Bus under voltage |
| D | General Power Supply/Soft Start fault |
| E | TBD |
| F | TBD |

Global Fault Only

In the case of a global fault only, the display will indicate the fault number from 8-F (hex). In the case of multiple global faults, the higher numbered fault will be displayed. The decimal point shall be off (pending possible future use).

Global and Axis-Specific Faults

In the case of an axis-specific fault and a global fault, the global fault shall be indicated.

Axis-Specific Fault Only

In the case of an axis-specific fault on any axis, the display will indicate the fault number from 1-7. The two decimal points shall be used to indicate which axis has the fault in the following manner:

| | | |
|----------------|----------|-----------|
| Axis 1: | Left off | Right off |
| Axis 2: | Left off | Right on |
| Axis 3: | Left on | Right off |
| Axis 4: | Left on | Right on |

In the case of multiple axis-specific faults on one axis, the higher-numbered fault shall be indicated.

In the case of axis-specific faults on multiple axes, the axis with the higher-numbered fault shall be displayed along with the decimal point indicting its axis number.

In the case of axis-specific faults of the same number on multiple axes, the fault number shall be displayed and decimal point indication shall specify the higher-numbered axis.

| Problem | Check | Corrective Action |
|---|--|---|
| Under voltage indicator comes on when power is applied. | This is a normal condition. | When AC power is first applied, the Soft Start has not been initialized and the bus is not charged. This results in a low line fault. The first enable command (usually 00) will initialize the Soft Start. The following CNTL K command will ensure that no motor is enabled. It will also turn the Soft Start IGBT on and allow the bus cap to charge. |
| Quad Amplifier enables normally but LED Fault Indicator displays C after a motor is moved. | Check if the bus voltage holds steady after an axis is enabled and/or moved | |
| Motor does not turn. | 1. Is the correct main AC power applied to the unit? | Apply correct AC power. |
| | 2. Is a motor connected? | Connect motor. |
| | 3. Is the power enable (E-Stop) switch closed at C1? | Close E-Stop switch. (If E-Stop not used, make sure a plug is installed on connector C1.) |
| | 4. Is PMAC2 connected, powered and working? | Connect, power up or replace PMAC2 if necessary. |
| | 5. Is the correct axis being commanded? | Command the correct axis. |
| | 6. Is there a fault indicated on the LED Fault Indicator? | Refer to the LED Fault Indicator fault codes and take the corrective action. |
| <p>Warning: At this point, it is necessary to remove the Quad Amplifier cover to further troubleshoot the unit. Every precaution should be taken to avoid serious injury from being exposed to high voltages.</p> | | |
| | 7. Is there a bus voltage? | Make sure the AC power is applied and check for DC bus voltage across 15 k Ohm bleed resistor on the filter capacitor box. |
| | 8. Are all logic supply LEDs (D5, D6, D7) on the logic and current sense boards lit? | An unlit power supply LED means that a supply is bad or missing. Check AC voltages at J5 of the Quad Amplifier logic board. Check if the cable between the logic board and the current sense board is connected. |
| | 9. Is the commanded axis enable LED (D18-D21 on logic board) lit? | Generally, enable LED comes on after #x00 command. Check if Ix00 is 1. |

| | | |
|---|--|--|
| <p>Motor moves after a command is issued but under voltage fault comes on shortly after. Also, the Soft Start resistor heats up (and possibly burns).</p> | <p>Verify if the bus voltage sags when the motor is commanded to move. The Main IGBT probably does not turn on. Check if the wiring between E1 and G1 (of Main IGBT) and J4-5, -6 (Soft Start board) is okay. Then verify if G1 with respect to E1 switches from approx. -10 VDC to +15 VDC after the Main power is turned on. If it does, the Main IGBT is probably open. If it does not, the problem is most likely with the Soft Start board.</p> | <p>Call Delta Tau for an RMA.</p> |
| <p>Under voltage fault stays displayed even after several enable commands.</p> | <p>Check if there is bus voltage across 15k Ohm bleed resistor.</p> | <p>If not, examine if the 10-pin flat cable between the Soft Start and the I/O Logic board is connected on both sides and in good shape.</p> |

ILLUSTRATED REPAIR PARTS LIST

Purpose

This chapter contains the Repair Parts List (RPL) for the 4-Axis Digital Amplifier (Quad Amplifier). The RPL identifies the customer replaceable units (CRUs) of Quad Amplifier with an illustration and a Group Assembly Parts List (GAPL).

Scope

The GAPL includes figure/index number; part number; description; true manufacturer and true manufacturer part number, if applicable, for each CRU of the Quad Amplifier. Replacement parts may be ordered from Delta Tau Data Systems, Inc. or by contacting the manufacturer or vendor listed.

How to Use the Repair Parts List

To effectively use the RPL, proceed as follows:

1. Find the item on the illustration and ascertain the item's index number.
2. Locate the index number on the Group Assembly Parts List table to identify the item, part number, and manufacturer.
 - To obtain replacement components, contact Delta Tau or the manufacturer. Manufacturers are listed in this section.

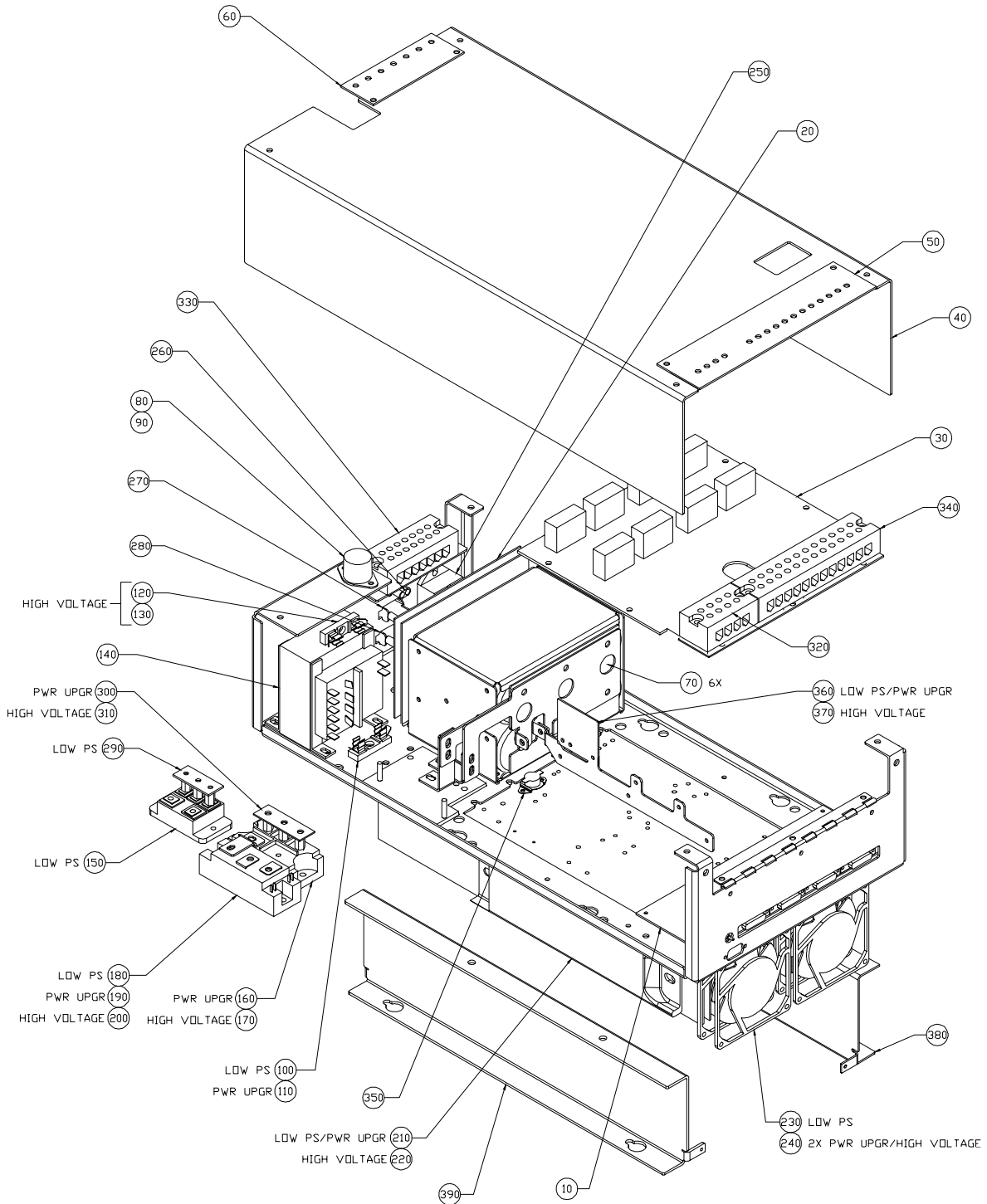

Figure 12 Delta Tau Data Systems 4 Axis Digital Amplifier

| Figure And Index Number | Part Number | Description | | | | | | Qty Per Assy | Manu- facturer | Part Number |
|----------------------------------|----------------|---|---|---|---|---|---|--------------------|-------------------|-----------------------|
| | | 1 | 2 | 3 | 4 | 5 | 6 | | | |
| 7-1 | 500-602645-103 | QUAD Digital Amplifier (Top Assy) | | | | | | | Delta Tau | |
| -10 | 300-602761-103 | PCBA, Logic I/O | | | | | | 1 | Delta Tau | |
| -20 | 400-602800-103 | Soft Start Assy | | | | | | 1 | Delta Tau | |
| -30 | 300-602677-102 | PCBA, Current Sense | | | | | | 1 | Delta Tau | |
| -40 | 200-602617-556 | Amplifier Cover | | | | | | 1 | Delta Tau | |
| -50 | 200-602737-551 | Plastic Cover (Motor Output) | | | | | | 1 | Delta Tau | |
| -60 | 200-602816-552 | Plastic Cover (AC Input Voltage) | | | | | | 1 | Delta Tau | |
| -70 | 007-400182-008 | Capacitor 1800UF/400V | | | | | | 1 | Nichicon | LNQ2G182MS M |
| -80 | 021-HPFRR1-000 | Fuse Holder (F201) | | | | | | 1 | Bussman | HPF-RR |
| -90 | 021-TK30R0-214 | Fuse, 30 AMP/600V | | | | | | 1 | Bussman | KTK-R-30 |
| -100 | 021-042431-000 | Fuse Holder (F202) | | | | | | 1 | Keystone | 4243 |
| -110 | 021-000004-0FS | Fuse 4A-SB 250V | | | | | | 1 | Little Fuse | 313004 |
| -120 | 021-BM6031-000 | Fuse Holder (F202) (Used on 380/460 Quad Amplifier) | | | | | | 1 | Bussman | BM6031SQ |
| -130 | 021-FN04Q4-004 | Fuse 4A 500V (Used on 380/460 Quad Amplifier) | | | | | | 1 | Bussman | FNQ-4 |
| -140 | 213-602647-100 | Control PWR Trans | | | | | | 1 | 3s Indust | 6000-63-1 |
| -150 | 005-580N40-3BR | Bridge Rect. 40A/800V (for standard power supply) | | | | | | 1 | Powerex | RM20TPM-H |
| -160 | 005-500810-0ME | Bridge Rect. 100A/800V (for upgraded power supply) | | | | | | 1 | Powerex | ME500810 |
| -170 | 005122100-3BR | Bridge Rect. 100A/1200V (for high voltage power supply) | | | | | | 1 | Powerex | ME501210 |
| -180 | 004-50D600-0HS | IGBT Switch 50A/600V (for standard power supply) | | | | | | 1 | Powerex | CM50DY-12H |
| -190 | 004-CM100-12H | IGBT Switch 100A/600V (for upgraded power supply) | | | | | | 1 | Powerex | CM100DY-12H |
| -200 | 044-75D122-0HS | IGBT Switch 75A/1200V (for high voltage power supply) | | | | | | 1 | Powerex | CM75DY-24H |
| -210 | 213-602646-100 | Int. Shunt Res. 30/900W (for standard and upgraded power supplies) | | | | | | 2 | Vulcan | None |
| -220 | 008-300060-000 | Int. Shunt Res. 60/300W (for high voltage power supply) | | | | | | 2 | Vulcan | None |
| -230 | 032-A30108-010 | 4.5" Dia. Cooling Fan 600V (for standard power supply) | | | | | | 1 | Nidec | A30108-10 |
| -240 | 032-115060-035 | 3.5" Dia. Cooling Fan 300W (for upgraded and high voltage power supplies) | | | | | | 2 | Nidec | 3610PS-12T- B30-A0 |
| -250 | 005-241250-0CS | Clamping Diode | | | | | | 1 | Powerex | CS241250 |
| -260 | 014-030M02-HSM | 2 Pos. Plug (P1) | | | | | | 1 | Amp | 1-480698-0 |

| Figure And Index Number | Part Number | Description | | | | | | | Qty Per Assy | Manu- facturer | Part Number |
|----------------------------------|----------------|-------------|---|---|---|---|---|---|--------------------|-------------------|------------------|
| | | 1 | 2 | 3 | 4 | 5 | 6 | 7 | | | |
| -270 | 014-030M03-HSM | | | | | | | | 1 | Amp | 1-480700-0 |
| -280 | 014-00MF04-0HM | | | | | | | | 1 | Amp | 1-480702-0 |
| -290 | 300-603001-100 | | | | | | | | 1 | Delta Tau | |
| -300 | 300-603000-100 | | | | | | | | 1 | Delta Tau | |
| -310 | 300-603000-100 | | | | | | | | 1 | Delta Tau | |
| -320 | 016-600V04-55A | | | | | | | | 1 | Marathon | 1104S |
| -330 | 016-MARA07-0TB | | | | | | | | 1 | Marathon | 985-GP-07 |
| -340 | 016-000012-600 | | | | | | | | 1 | Marathon | 1112S |
| -350 | 028-08A180-NCS | | | | | | | | 1 | Elmwood | 3450-88-142-L180 |
| -360 | 301-602815-101 | | | | | | | | 1 | Delta Tau | |
| -370 | 301-602815-101 | | | | | | | | 1 | Delta Tau | |
| -380 | 200-602625-554 | | | | | | | | 1 | Delta Tau | |
| -390 | 200-602626-554 | | | | | | | | 1 | Delta Tau | |